



**PRACTICAL USER'S GUIDE
FOR THE
SUB-COMPACT STOVE**

**MODEL NUMBER:
CS1205**

Serial Number _____

Model Number _____

CAT Number _____

Quality checked by:

Valued Customer,

We are pleased that you have chosen to purchase an electric fireplace product manufactured by Electralog.

Over the years, valuable memories will occur around the warmth and comfort of your hearth. Thank you for allowing our product to be the backdrop for those special moments.

7207040100REV03

QUICK REFERENCE GUIDE

1. Prior to the first use of the Sub-Compact Stove verify the following:
 - Are the circuit breakers for the unit on?
 - Are the light bulbs in your Sub-Compact Stove loose?
(to check, follow the instructions for replacing the light bulbs under the Maintenance section of this manual)
2. The heater on your Sub-Compact Stove may emit a slight, harmless odor when first used. This odor is a normal condition caused by the initial heating of internal heater parts and will not occur again.
3. The information regarding the model of your Sub-Compact Stove can be found on the rating plate located on the back of the unit.
4. If you have any technical questions or concerns regarding the operation of your Sub-Compact Stove, or require service contact Customer Service at 1-888-346-7539 before returning the product to the point of purchase.

CONTENTS

PAGE 1	Important Instructions
PAGE 2	Model and Serial Number Information
PAGE 3	Sub-Compact Stove Installation
PAGE 3	Operation
PAGE 4	Maintenance
PAGE 6	Warranty

IMPORTANT INSTRUCTIONS

PLEASE RETAIN THIS USER'S GUIDE FOR FUTURE REFERENCE

When using electrical appliances, basic precautions should always be followed to reduce the risk of fire, electric shock, and injury to persons, including the following:

1. Read all instructions before using the Sub-Compact Stove.
2. The heater is hot when in use. To avoid burns, do not let bare skin touch hot surfaces. The trim around the heater outlet becomes hot during heater operation. Keep combustible materials, such as furniture, pillows, bedding, papers, clothes, and curtains at least 3 feet (0.9m) from the front of the unit.

CAUTION: High Temperature. Keep electrical cords, drapery, and other furnishings at least 3FT (0.9m) from the front of the heater and away from the side and rear.

3. Extreme caution is necessary when any heater is used by or near children or invalids and whenever the unit is left operating and unattended.
4. Always unplug the Sub-Compact Stove when not in use.
5. Do not operate any unit with a damaged cord or plug, or if the heater has malfunctioned, or if the Sub-Compact Stove has been dropped or damaged in any manner. Return heater to authorized service facility for examination, electrical or mechanical adjustment, or repair.

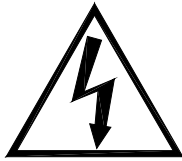

CAUTION
RISK OF ELECTRIC SHOCK
DO NOT OPEN
NO USER-SERVICEABLE PARTS INSIDE



6. Do not use outdoors.
7. The Sub-Compact Stove is not intended for use in bathrooms, laundry areas and similar indoor locations. Never locate heater where it may fall into a bathtub or other water container.
8. Do not run the cord under carpeting. Do not cover cord with throw rugs, runners, or the like. Arrange cord away from traffic area and where it will not be tripped over.
9. To disconnect the unit, turn the controls off, then remove the plug from the outlet.
10. Do not insert or allow foreign objects to enter any ventilation or exhaust opening as this may cause an electric shock or fire, or damage to the heater.
11. To prevent a possible fire, do not block air intake or exhaust in any manner. Do not use on soft surfaces, like a bed, where openings may become blocked.
12. All electrical heaters have hot and arcing or sparking parts inside. Do not use in areas where gasoline, paint, or flammable liquids are used or stored or where the unit will be exposed to flammable vapors.
13. Do not modify the Sub-Compact Stove. Use it only as described in this manual. Any other use not recommended by the manufacturer may cause fire, electric shock or injury to persons.
14. To reduce the risk of electric shock, this appliance has a polarized plug (one blade is wider than the other). This plug will fit in a polarized outlet only one way. If the plug does not fit fully in the outlet, reverse the plug. If it still does not fit, contact a qualified electrician to install the proper outlet. Do not change the plug in any way. Avoid the use of an extension cord. Extension cords may overheat and cause a risk of fire. If you must use an extension cord, the cord must be No. 16 AWG minimum size and rated no less than 1875 watts.
15. Do not burn wood or other materials in the Sub-Compact Stove.
16. Do not strike the clear door panel.
17. Always use a certified electrician should new circuits or outlets be required.
18. Always use properly grounded, fused and polarized outlets.
19. Disconnect all power supply before performing any cleaning, maintenance or relocation of the unit.
20. When transporting or storing the unit and cord, keep in a dry place, free from excessive vibration and store so as to avoid damage.

SAVE THESE INSTRUCTIONS

NOTE: Procedures and techniques that are considered important enough to emphasize.

CAUTION: Procedures and techniques which, if not carefully followed, will result in damage to the equipment.

WARNING: Procedures and techniques which, if not carefully followed, will expose the user to the risk of fire, serious injury, illness or death.

MODEL AND SERIAL NUMBER INFORMATION

If you have any questions about our products please have the CAT/model and serial numbers available upon calling Customer Service. The CAT/model and serial numbers are located on the back of the unit (refer to FIGURE 1 below). Record the Model Number, Serial Number, and CAT number on the front cover of this manual for future reference.

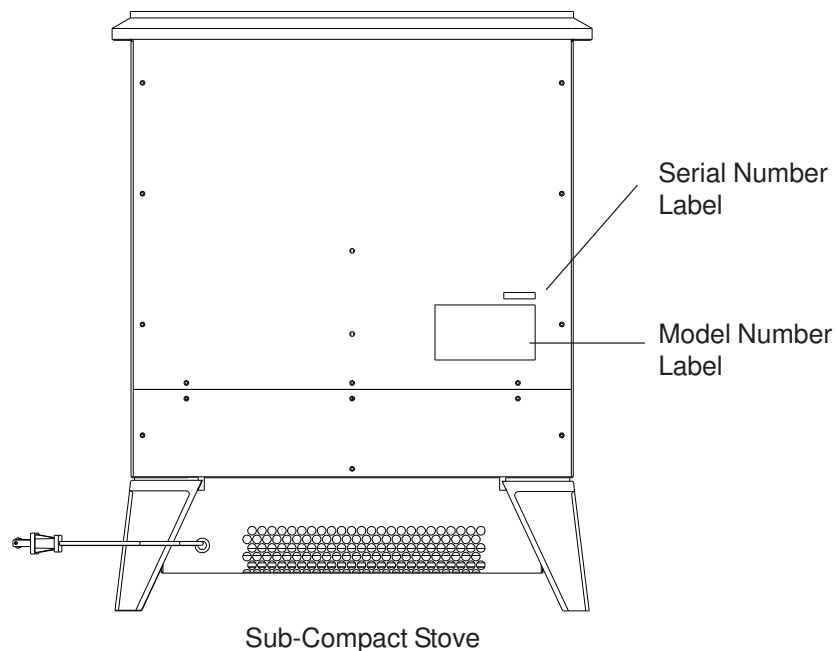
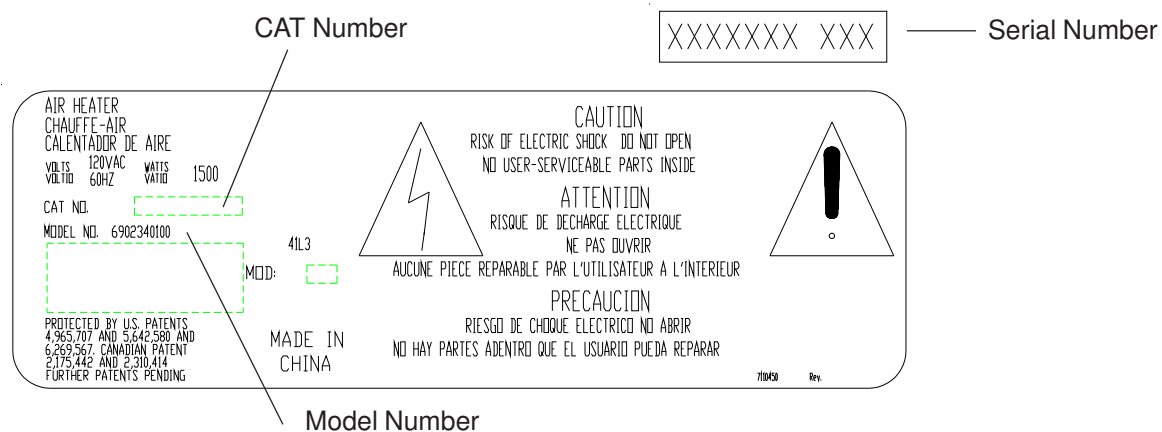

FIGURE 1

NOTE

A 15 Amp, 120 Volt alternating current (VAC) circuit is required. A dedicated circuit is preferred but not essential in all cases. A dedicated circuit will be required if, after installation, the circuit breaker trips or blows fuses on a regular basis when the heater is operating. Additional appliances on the same circuit may exceed the current rating of the circuit breaker.

WARNING

Ensure the power cord is not installed so that it is pinched or against a sharp edge and ensure that the power cord is stored or secured to avoid tripping or snagging to reduce the risk of fire, electric shock or injury to persons.

Construction and electrical wiring must comply with local building codes and other applicable regulations to reduce the risk of fire, electric shock and injury to persons.

Do not attempt to wire your own new outlets or circuits. To reduce the risk of fire, electric shock or injury to persons, always use a licensed electrician.

SUB-COMPACT STOVE INSTALLATION

1. Make sure the unit's MAIN ON/OFF switch is switched OFF (refer to operating instruction section).
2. Plug the unit into a 15 Amp/120 VAC outlet. If the cord does not reach, you may use an extension cord rated for a minimum of 1875 Watts.

OPERATION

The controls are located on the right side of the heater pan. (FIGURE 2)

A. MAIN ON/OFF SWITCH

The ON/OFF switch supplies power to all unit functions (heat/flame)

B. LOW HEAT SWITCH

The LOW HEAT ON/OFF SWITCH supplies power to the heater fan and the heater element. When the switch is in the ON position the heater operates on LOW.

C. HIGH HEAT SWITCH

The HIGH HEAT ON/OFF SWITCH supplies power to the heater fan and the heater element, when the switch is in the ON position the heater operates on HIGH. The LOW HEAT ON/OFF SWITCH must also be in the ON position for the high heat setting to operate.

FIGURE 2

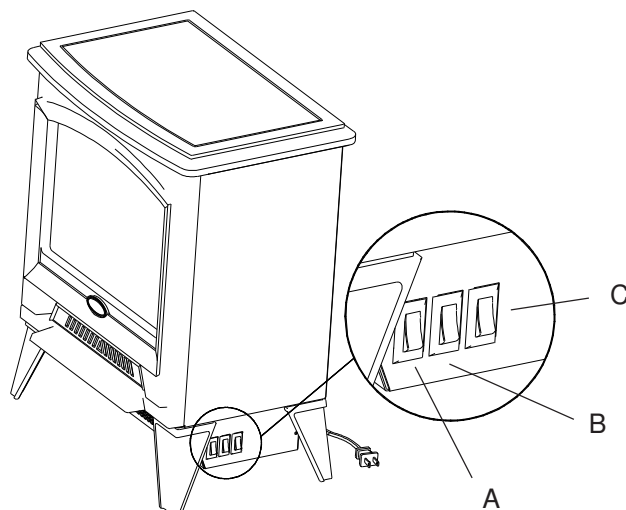

RESETTING THE TEMPERATURE CUTOFF SWITCH

Should the heater overheat, an automatic cut out will turn the heater off and it will not come back on without being reset. It can be reset by switching the MAIN ON/OFF SWITCH to OFF and waiting 5 minutes before switching the unit back on.

CAUTION

If you need to continuously reset the heater, unplug the unit and call Customer Service at 1-888-346-7539.

MAINTENANCE

WARNING

Disconnect power before attempting any maintenance or cleaning to reduce the risk of fire, electric shock or injury to persons.

HELPFUL HINTS

It is a good idea to replace all light bulbs at one time if they are close to the end of their rated life. Group replacement will reduce the number of times you need to open the unit to replace light bulbs.

LIGHT BULB REPLACEMENT

Allow at least 5 minutes for the light bulb to cool off before touching, to avoid accidental burning of the skin. The light bulb needs to be replaced when you notice a dark section of the flame or when the clarity and detail of the log exterior disappears. There is one bulb located at the back of the unit behind the access panel.

LOWER LIGHT BULB REQUIREMENTS

Quantity of 1 clear chandelier or candelabra bulb with an E-12 (small) socket base, and 60 Watt rating.

TO REPLACE THE LIGHT BULB (FIGURE 3)

1. Remove the five screws from the access panel, located on the back of the unit, and remove access panel.
2. Locate and examine the bulb to determine if replacement is required.
3. Unscrew the bulb counter clockwise.
4. Insert new bulb.
5. Secure access panel to unit.

FIGURE 3

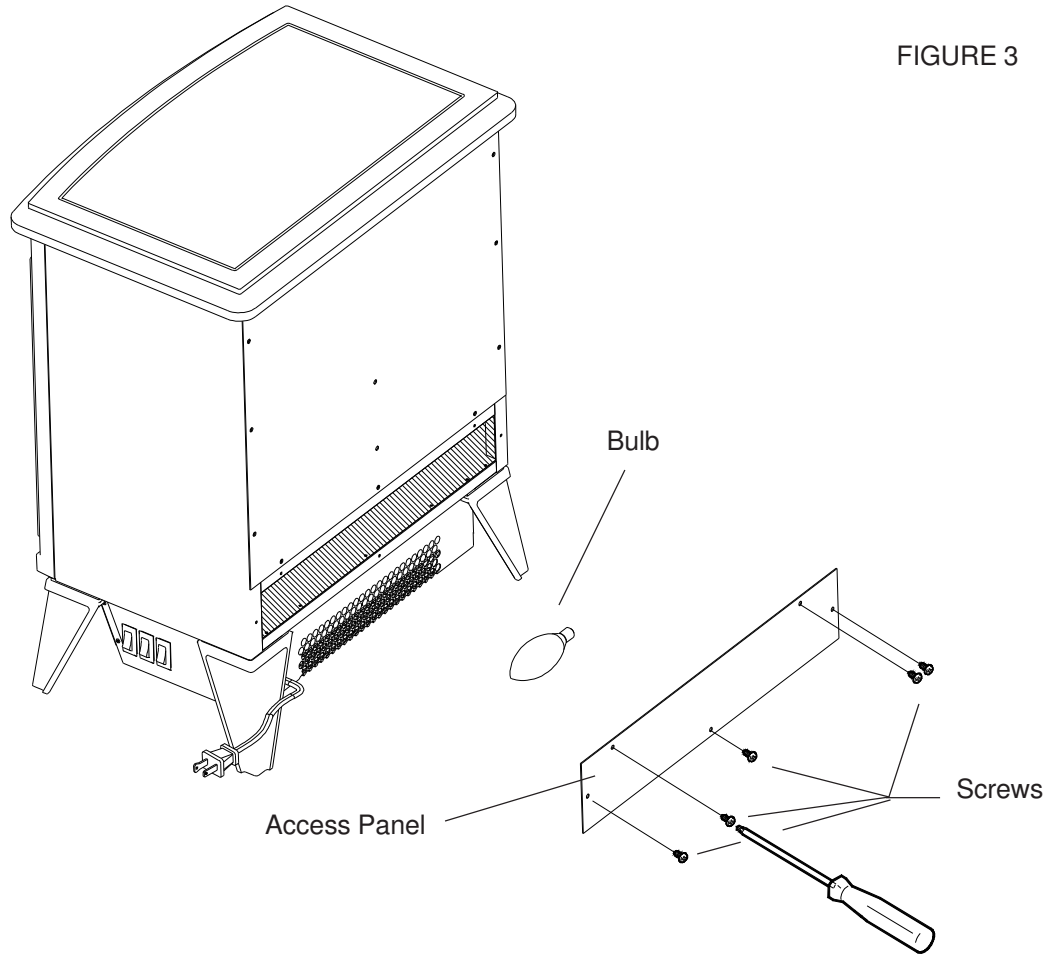

CLEAR DOOR PANEL CLEANING

The clear door is cleaned in the factory during the assembly operation. During shipment, installation, handling, etc., the clear door may collect dust particles. These can be removed by dusting lightly with a clean, dry cloth.

To remove fingerprints or other marks, the clear doors can be cleaned with a damp cloth. The clear door should be completely dried with a lint free cloth to prevent water spots. To prevent scratching, do not use abrasive cleaners or spray liquids on the clear door surface.

SUB-COMPACT STOVE SURFACE CLEANING

Use warm water only to clean painted surfaces of the Sub-Compact Stove. Do not use abrasive cleaners.

SERVICING

Except for light bulb replacement and cleaning described above, an authorized service representative should perform any other servicing.

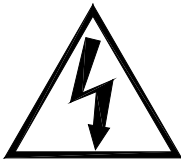

CAUTION
RISK OF ELECTRIC SHOCK
DO NOT OPEN
NO USER-SERVICEABLE PARTS INSIDE



ONE YEAR LIMITED WARRANTY

Products to which this limited warranty applies

This limited warranty applies to the following models of your newly purchased **Electralog Sub-Compact Stove CS1205** and to newly purchased Electralog fireplace surrounds (mantels) and trims. This limited warranty applies only to purchases made in any province of Canada *except* for Yukon Territory, Nunavut, or Northwest Territories or in any of the 50 States of the USA (and the District of Columbia) *except* for Hawaii and Alaska. This limited warranty applies to the original purchaser of the product only and is not transferable.

Products excluded from this limited warranty

Light bulbs are not covered by this limited warranty and are the sole responsibility of the owner/purchaser. Products purchased in Yukon Territory, Nunavut, Northwest Territories, Hawaii, or Alaska are not covered by this limited warranty. Products purchased in these States, provinces, or territories are sold AS IS without warranty or condition of any kind (including, without limitation, any implied warranties or conditions of merchantability or fitness for a particular purpose) and the entire risk of as to the quality and performance of the products is with the purchaser, and in the event of a defect the purchaser assumes the entire cost of all necessary servicing or repair.

What this limited warranty covers and for how long

Products covered by this limited warranty have been tested and inspected prior to shipment and, subject to the provisions of this warranty, Electralog warrants such products to be free from defects in material and workmanship for a period of 12 months from the date of the first purchase of such product.

The limited 12 month warranty period also applies to any implied warranties that may exist under applicable law. Some jurisdictions do not allow limitations on how long an implied warranty lasts, so the above limitation may not apply to the purchaser.

What this limited warranty does not cover

This limited warranty does not apply to products that have been repaired (except by Electralog or its authorized service representatives) or otherwise altered. This limited warranty does further not apply to defects resulting from misuse, abuse, accident, neglect, incorrect installation, improper maintenance or handling, or operation with an incorrect power source.

What you must do to get service under this limited warranty

Defects must be brought to the attention of Electralog Technical Service by contacting Electralog at 1-888-346-7539, or 1367 Industrial Road, Cambridge Ontario, Canada N1R 7G8. Please have proof of purchase, catalogue/model and serial numbers available when calling. Limited warranty service requires a proof of purchase of the product.

What Electralog will do in the event of a defect

In the event a product or part covered by this limited warranty is proven to be defective in material or workmanship during the 12 month limited warranty period you have the following rights:

- Electralog will in its sole discretion either repair or replace such defective product or part without charge. If Electralog is unable to repair or replace such product or part, or if repair or replacement is not commercially practicable or cannot be timely made, Electralog may, in lieu of repair or replacement, choose to refund the purchase price for such product or part.

- Limited warranty service will be performed solely by dealers or service agents of Electalog authorized to provide limited warranty services
- The purchaser is responsible for removal and transportation of such product or part (and any repaired or replacement product or part) to and from the authorized dealer's or service agent's place of business.
- This limited warranty does not entitle the purchaser to on-site or in-home services. On-site or in-home services may be performed at the purchaser's specific request and expense at Electalog's then-current rates for such services.
- Electalog will not be responsible for, and the limited warranty services shall not include, any expense incurred for installation or removal of the product or part (or any replacement product or part) or any labour or transportation costs. Such costs shall be the purchaser's responsibility.

What Electalog and its dealers and service agents are also not responsible for:

IN NO EVENT WILL ELECTRALOG, OR ITS DIRECTORS, OFFICERS, OR AGENTS, BE LIABLE TO THE PURCHASER OR ANY THIRD PARTY, WHETHER IN CONTRACT, IN TORT, OR ON ANY OTHER BASIS, FOR ANY INDIRECT, SPECIAL, PUNITIVE, EXEMPLARY, CONSEQUENTIAL, OR INCIDENTAL LOSS, COST, OR DAMAGE ARISING OUT OF OR IN CONNECTION WITH THE SALE, MAINTENANCE, USE, OR INABILITY TO USE THE PRODUCT, EVEN IF ELECTRALOG OR ITS DIRECTORS, OFFICERS, OR AGENTS HAVE BEEN ADVISED OF THE POSSIBILITY OF SUCH LOSSES, COSTS OR DAMAGES, OR IF SUCH LOSSES, COSTS, OR DAMAGES ARE FORESEEABLE. IN NO EVENT WILL ELECTRALOG, OR ITS OFFICERS, DIRECTORS, OR AGENTS BE LIABLE FOR ANY DIRECT LOSSES, COSTS, OR DAMAGES THAT EXCEED THE PURCHASE PRICE OF THE PRODUCT.

SOME JURISDICTIONS DO NOT ALLOW THE EXCLUSION OR LIMITATION OF INCIDENTAL OR CONSEQUENTIAL DAMAGES, SO THE ABOVE LIMITATION OR EXCLUSION MAY NOT APPLY TO THE PURCHASER.

How State and Provincial law apply

This limited warranty gives you specific legal rights, and you may also have other rights which vary from jurisdiction to jurisdiction. The provisions of the United Nations Convention on Contracts for the Sale of Goods shall not apply to this limited warranty or the sale of products covered by this limited warranty.



Approved for use in the United States and Canada

1-888-346-7539

electralog[®]

1367 Industrial Road
Cambridge, Ontario
Canada, N1R 7G8