

# Cuisinart®

## INSTRUCTION BOOKLET



**Cuisinart Classic™ 12-Cup (1.8 L)  
Programmable Coffeemaker**

**DCC-1100C Series**

For your safety and continued enjoyment of this product, always read the instruction book carefully before using.

# IMPORTANT SAFEGUARDS

When using electrical appliances, basic safety precautions should always be followed to reduce the risk of fire, electric shock and/or injury to persons, including the following:

1. **READ ALL INSTRUCTIONS.**
2. Do not touch hot surfaces. Use handles and knobs.
3. To protect against electric shock, do not place cord, plug, or base in water or other liquids.
4. Close supervision is necessary when any appliance is used by or near children.
5. **Always unplug from outlet when not in use and before cleaning.** Allow to cool before putting on or taking off parts and before cleaning the appliance.
6. Do not operate any appliance with a damaged cord or plug or after the appliance malfunctions or has been dropped or damaged in any manner. Return appliance to the nearest Cuisinart Repair Centre for examination, repair, or electrical or mechanical adjustment.
7. The use of accessory attachments not recommended by Cuisinart may cause injuries.
8. Do not use outdoors.
9. Do not let cord hang over edge of table or counter, or touch any hot surface.
10. Do not place on or near a hot gas or electric burner, or in a heated oven.
11. Always fill water reservoir first, then plug cord into the wall outlet. To disconnect, turn controls to off, then remove plug from wall outlet.

12. Do not use appliance for other than intended use.
13. Snap lid securely onto carafe before serving any beverages.
14. Scalding may occur if the lid is removed during the brewing cycle.
15. The glass carafe is designed for use with appliance base only. It must never be used on the range top.
16. Do not set a hot carafe on a wet or cold surface.
17. Do not use a cracked carafe or a carafe having a loose or weakened handle.
18. Do not clean carafe or warming plate with cleansers, steel wool pads, or other abrasive materials.
19. **WARNING: TO REDUCE THE RISK OF FIRE OR ELECTRIC SHOCK, DO NOT REMOVE THE BASE PANEL. NO USER SERVICEABLE PARTS ARE INSIDE. REPAIR SHOULD BE DONE ONLY BY AUTHORIZED PERSONNEL.**
20. Avoid contact with moving parts.

## WARNING: RISK OF FIRE OR ELECTRIC SHOCK

The lightning flash with arrowhead symbol within an equilateral triangle is intended to alert the user to the presence of uninsulated dangerous voltage within the product's enclosure that may be of sufficient magnitude to constitute a risk of fire or electric shock to persons.



The exclamation point within an equilateral triangle is intended to alert the user to the presence of important operating and maintenance (servicing) instructions in the literature accompanying the appliance.

# SAVE THESE INSTRUCTIONS FOR HOUSEHOLD USE ONLY

## SPECIAL CORD SET INSTRUCTIONS

A short power-supply cord is provided to reduce the risks resulting from becoming entangled in or tripping over a longer cord.

Longer extension cords are available and may be used if care is exercised in their use.

If a long extension cord is used, the marked electrical rating of the extension cord must be at least as great as the electrical rating of the appliance, and the longer cord should be arranged so that it will not drape over the countertop or tabletop where it can be pulled on by children or tripped over.

## NOTICE

This appliance has a polarized plug (one blade is wider than the other). To reduce the risk of electric shock, this plug will fit in a polarized outlet only one way. If the plug does not fit fully in the outlet, reverse the plug. If it still does not fit, contact a qualified electrician. Do not modify the plug in any way.

## OPERATING NOTICE

Clogging and backing up of water and/or coffee in the filter basket can occur under any or a combination of any of the following conditions: The use of too finely ground coffee, using two or more paper filters, using the gold tone filter in conjunction with a paper filter or not properly cleaning coffee grounds from the gold tone filter, or allowing coffee grounds to spill over the filter.

**Caution:** Never open the reservoir cover during the brewing cycle, even if no water is draining from the filter basket, since extremely hot water/coffee can spill out from the basket and cause injury. If water/coffee is not draining from the filter basket during the brewing cycle, unplug the unit and wait 10 minutes before opening the reservoir cover and checking the basket.

## IMPORTANT UNPACKING INSTRUCTIONS

1. Place the box on a large, sturdy, flat surface.
2. Remove the instruction book and any other literature.
3. Turn the box so that the back side of the coffeemaker is down and slide the coffeemaker from the box.
4. After the coffeemaker has been removed, place the box out of the way and remove the top and bottom two polyfoam inserts.
5. Grasp the carafe by its handle, remove it from the heater plate and remove the polybag.



## WARNING

RISK OF FIRE OR ELECTRIC SHOCK  
DO NOT OPEN



**WARNING: TO REDUCE THE RISK OF FIRE OR ELECTRIC SHOCK, DO NOT REMOVE COVER (OR BACK)  
NO USER-SERVICEABLE PARTS INSIDE  
REPAIR SHOULD BE DONE BY AUTHORIZED SERVICE PERSONNEL ONLY**

- Remove the polybag covering from the coffeemaker and lift the coffeemaker off the remaining two inserts.

We suggest you save all packing materials in the event that future shipping of the machine is needed. Keep all plastic bags away from children.

## CONTENTS

Important Safeguards .....	2
Unpacking Instructions .....	3
The Quest for the Perfect Cup of Coffee .....	4
Features and Benefits .....	5
Control Panel .....	6
Programming Your Coffeemaker .....	7
Making Coffee .....	7
Cleaning and Maintenance .....	9
Warranty .....	10

## INTRODUCTION

You'll love the way your new Cuisinart Classic™ 12-Cup Programmable Coffeemaker looks on your counter, as it's brewing 12 cups (1.8 L) of fabulous coffee. The Cuisinart Classic™ 12-Cup (1.8 L) Programmable Coffeemaker is a statement about how serious you are about your coffee – and your kitchen. Enjoy the full programmability, extreme ease of use, and great tasting coffee.

## THE QUEST FOR THE PERFECT CUP OF COFFEE

It is generally agreed that there are four basic elements critical to the perfect cup:

### Element 1: Water

Coffee is 98% water. Often overlooked, the quality of the water is as important as the quality of the coffee. A good rule of thumb is that if your water doesn't taste good from the tap, it won't taste any better in your coffee. That's why Cuisinart has added a water filter to the Cuisinart Classic™ 12-Cup (1.8 L) Programmable Coffeemaker. The charcoal water filter removes chlorine, calcium, bad tastes and

odors, for the purest cup of coffee every time.

### Element 2: Coffee

While the bulk of the liquid is water, all of the flavour should be from the coffee. To achieve the same great quality cup of coffee you receive at a coffee bar, you need to use the same quality beans. If you choose to grind your own beans, buy the beans fresh and whole, only about a two-week supply at a time for maximum freshness. Once the coffee bean is broken, its flavour degrades very quickly. If it is not practical to buy small supplies, we recommend you separate larger amounts of beans into one- to two-week portions immediately after purchasing, and freeze them in airtight containers. The best way to maximize freshness is to minimize exposure to air, light and moisture. So, once removed from the freezer, beans should be maintained in a sealed container at room temperature, since damaging condensation occurs every time the beans are removed from the freezer or refrigerator. Note that some coffee experts advise against freezing dark-roast beans because this can cause the oils to coagulate, while other experts disagree. We suggest you experiment and decide for yourself.

### Element 3: Grind

The grind is critical for proper flavour extraction. If the grind is too fine, overextraction and bitterness will result. Too fine a grind may also clog your filter. If grind is too coarse, the water will pass through too quickly and the desired flavours will not be extracted. We recommend a medium-fine grind.

### Element 4: Proportion

The cups on the Cuisinart® coffeemaker are 5 ounces (148 ml). Add the amount of ground coffee that corresponds to the number of cups being brewed. Many coffee bars and the Specialty Coffee Association of America recommend adding 2 rounded tablespoons (30 ml) of coffee per 6 ounces (170 ml) of water. Some coffee manufacturers recommend using 1 tablespoon (15 ml) per cup. We recommend using 1 tablespoon (15 ml) of ground coffee per cup, but use more or less to suit your taste.

**NOTE: The maximum capacity for ground**

**coffee is 15 tablespoons (225 ml) for this 12-cup (1.8 L) coffeemaker. Exceeding this amount may cause overflow if the coffee is too finely ground.**

## FEATURES AND BENEFITS

- Reservoir Cover**  
Flips back for easy filling.
- Water Reservoir**
- Showerhead (not shown)**  
Distributes water evenly over coffee, reducing temperature loss as water passes through grounds.
- Water Filter (not shown)**  
Charcoal water filter eliminates chlorine, calcium and bad tastes and odours from tap water.
- Filter Basket (not shown)**  
Holds a #4 paper filter or a permanent filter.
- Filter Basket Holder (not shown)**
- LCD Digital Clock**  
Displays time of day and set time for automatic functions.
- Hour and Minute Buttons**  
Used to set time of day and automatic functions.
- Function Knob**  
Used to initiate programming of automatic functions – Auto On, Auto Off, Program, Clock, and Brew.
- On/Off Button**  
Used to turn your coffeemaker on and off and program your delayed brew.
- 1-4 Cup Setting**  
For brewing smaller pots of coffee. It provides double heating of the water, so coffee is piping hot.
- Clean Setting**  
Tells you when it's time to clean your coffeemaker. Remove built-up calcification from the water reservoir, to help extend the life of your coffeemaker.
- Brew Pause™**  
Stops flow of coffee from basket when carafe is removed (30 seconds max) from

the heater plate, so a cup can be poured in mid-brew. Since the flavour extraction rate varies during the brew cycle, we recommend allowing the brewing cycle to finish before pouring the coffee.

- Carafe**  
The easy-pour, no-drip 12-cup (1.8 L) carafe has an ergonomic handle and brewed coffee markings for two to twelve cups.
- Heating Plate**  
Scratch resistant with black, nonstick coating.
- Ready Tone (not shown)**  
Signals the end of the brew cycle with five beeps.
- Cord Storage (not shown)**
- Power Loss Back-up System (not shown)**  
One-minute protection in case power fails, breaker trips, or unit is unplugged.
- Measuring Scoop (not shown)**

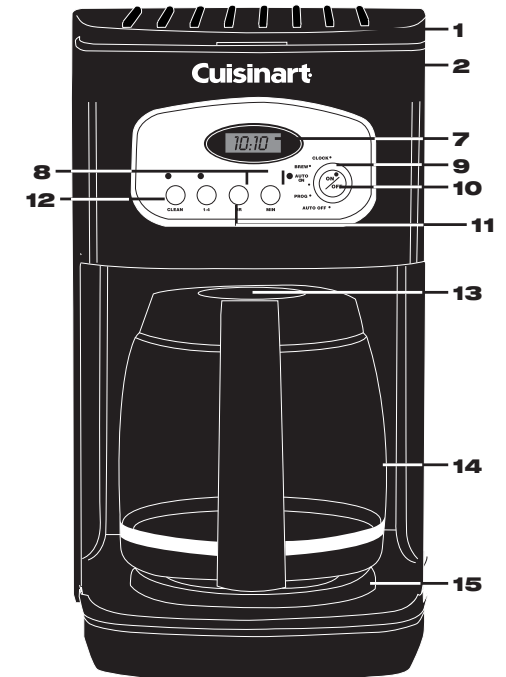

## CONTROL PANEL

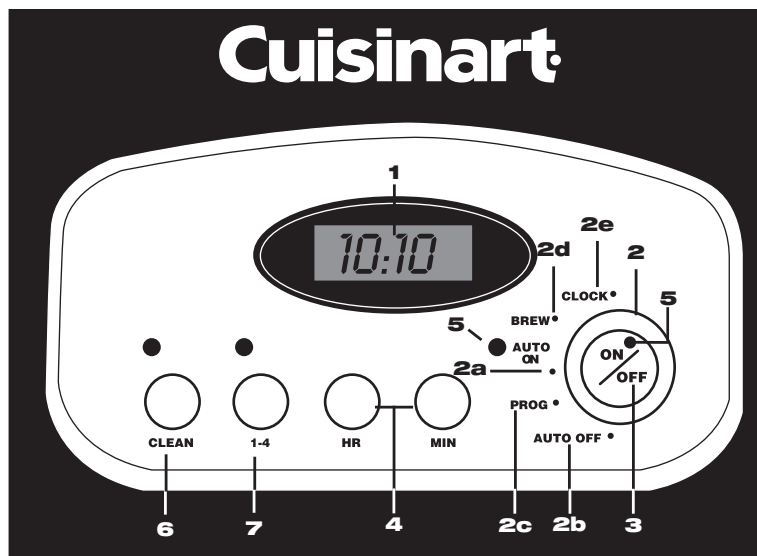

### 1. Clock Display

Displays time of day and auto on time.

### 2. Function Knob

For setting time of day, and auto on time.

#### a. Auto On

The Auto On feature is used to program the start time of the brew cycle. The auto on time can be set for any time, day or night. The PM indicator is displayed on the LCD for nighttime program times.

#### b. Auto Off

The Auto Off feature is used to shut off the coffeemaker at a preset time, anywhere from 0 to 4 hours.

#### c. Program Set

The Program Set function is used to set the time for the Auto On function.

#### d. Brew

The Brew function is used to start the brew cycle directly.

#### e. Clock Set

Used to program the time of day.

### f. Audible Tone (not shown)

The Cuisinart Classic™ 12-Cup (1.8 L) Programmable Coffeemaker is equipped with an audible tone which will sound 5 times when the coffee has completed brewing (coffee will continue to stream from the filter for a few seconds after tone).

### 3. On/Off Button

Used to turn your coffeemaker on and off; also works in tandem with the function knob.

### 4. Hour and Minute Buttons

For use in setting hour and minute for time of day, and auto on time.

### 5. On/Off and Auto On Indicator Lights

### 6. Clean Setting

Used to indicate time to clean your coffeemaker to remove calcium buildup.

### 7. 1-4 Cup Setting

For brewing smaller pots of coffee – it provides double heating of the water, so coffee is piping hot.

## PROGRAMMING YOUR COFFEEMAKER

### TO BREW COFFEE

1. Turn the function knob to “Brew.”
2. Press the On/Off button and release. The red On indicator light will illuminate and brew cycle will begin.

### TO TURN THE COFFEEMAKER OFF

Press the On/Off button and release.

**Note:** To program the coffeemaker to shut off automatically, see **To program the Variable Auto Off** instructions below.

### PROGRAMMING YOUR COFFEEMAKER FOR DELAYED BREW TIME

#### To set the time:

1. Turn the function knob to “Clock.”
  - a. **Set Hour:** Press and hold the Hour button to scroll through numbers quickly. When number displayed approaches the desired setting, press and release (pulse) the button to advance one digit at a time. After setting the correct hour, the default will be the last time set unless power is shut off.
  - b. **Set Minutes:** Press and hold the Minute button to scroll through numbers quickly. When number displayed approaches the desired setting, press and release (pulse) the button to advance one digit at a time. After setting the correct minute, the default will be the last time set unless power is shut off. To finish setting time, turn the Function Knob to any other setting or simply wait until the numbers stop blinking.

**NOTE:** When the number count passes 12, the PM light will be displayed on the LCD.

#### To program the Auto On (brew start time)

1. Turn the function knob to “Prog.”
2. Set the time you want coffee to begin brewing by using the minute and hour push-buttons. Follow the same instructions you used to set the time of day, in the **To set the time** section above.

3. Turn the function knob to “Auto On.” LCD will display the current time.
4. Press the On/Off button and release. The green indicator light will come on to remind you that the programming function is in use. At the programmed time, the red indicator will come on as well, indicating that the brew cycle is starting. Both lights will go off when keep warm cycle ends.

**NOTE:** To reactivate the auto-on feature to start brew cycle at the same time another day, simply press the On/Off button and release. The green Auto-On light will illuminate.

#### To program the Variable Auto Off

1. Turn the function knob to “Auto Off.” Press and hold the “Hour” button for 2 seconds. The clock display will start blinking.
2. Program the coffeemaker to shut off from zero to four hours after brew cycle is finished by using the Hour and Minute buttons (see **To set the time**).

#### 1 - 4 Cup Setting

The 1-4 cup setting button is used when you make small amounts of coffee. The 1-4 cup setting basically double heats the water, making your smaller amount piping hot.

**To use:** When making a smaller amount, press the 1-4 button on the control panel after turning on the unit.

#### Power Loss Back-up

One-minute protection in case a breaker trips, the unit is unplugged, or the power fails. It holds all programmed information, including time of day, auto on time and auto off time.

## MAKING COFFEE

Before you make the first pot of coffee in your new Cuisinart® coffeemaker, we recommend operating the coffeemaker once using only water and a paper filter. This will remove any dust or residues that remain in the system from the manufacturing process.

#### 1. Insert the Water Filter

- a. Remove the filter from polybag and soak in cold tap water for 15 minutes.

- b. Remove the water filter holder from the coffeemaker by lifting it out of the reservoir area with your thumb and forefinger.
- c. Hold the water filter holder lengthwise and place thumbs in slots directly under arrows.
- d. Pull open in opposite directions with thumbs.
- e. Place the filter in the holder recess area at the bottom of the water filter holder.

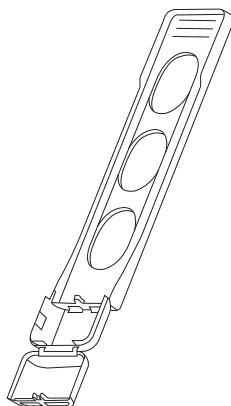

**NOTE:** Caution must be used when inserting the charcoal water filter. Improper placement in the holder can cause tearing of the filter skin.

- f. Close the water filter holder; you will hear a snap indicating it is in place.
- g. Hold the filter under cold running tap water for 10 seconds to flush. You should place the hole openings in the side of the unit directly under the water stream.
- h. Allow the filter to drain completely.
- i. Replace the water filter holder in the reservoir area of the coffeemaker, pushing it all the way down to the base of the unit.

**NOTE:** We recommend changing the water filter every 60 days or 60 uses – more often if you have hard water.

Replacement water filters can be purchased in stores, by calling customer service at 1-800-472-7606.

#### 2. Fill the water reservoir

Open the reservoir cover by lifting it up. Pour the desired amount of water in the reservoir using the step water level indicator located at the rear of the reservoir.

#### 3. Add the ground coffee

Remove the filter basket by grasping the handle and lifting straight up, and then place it on the countertop. Insert a #4 paper filter or permanent filter. Be sure that the paper filter is completely open and fully inserted in the basket. It may help to fold and flatten the seams of a paper filter beforehand. Add the desired amount of ground coffee, corresponding to the number of cups being brewed. Many coffee bars and the Specialty Coffee Association of America recommend adding 2 rounded tablespoons (30 ml) of coffee per 6 ounces (170 ml) of water. Some coffee manufacturers recommend using 1 tablespoon (15 ml) per cup. We recommend using 1 tablespoon (15 ml) of ground coffee per cup, but use more or less to suit your taste.

**NOTE: The maximum capacity for ground coffee is 15 tablespoons (225 ml) for this coffeemaker. Exceeding this amount may cause overflow if the coffee is too finely ground.**

Replace the filter basket in the filter basket holder and flip the water reservoir cover closed. Press firmly on cover to be sure that it closes securely.

#### Before brewing coffee

Make sure you have replaced the glass carafe in its position on the heating plate and closed the top cover. Plug the cord into an electrical outlet.

#### 4. Power unit

Turn the function knob to brew, press the on/off button, and the red indicator light will turn on. Or, set the Auto On function and the green indicator will light.

#### 5. During and after brewing

The Brew Pause™ feature allows you to remove the carafe from the plate during mid-brew. The brewing process does not stop during this period – only the flow of coffee from the basket stops. Do not remove the carafe for longer than 30 seconds or the coffee may overflow the basket. While we offer this feature, we do not recommend that you pour the coffee before the cycle has reached completion, since the coffee brewed at the beginning of the cycle has a flavour profile which is very different from the flavour at the end of the cycle. Removing a cup during the brewing cycle will alter the flavour of the finished pot.

Once the coffee has finished brewing, stir it before serving to blend the flavours. The coffee at the bottom of the carafe will be somewhat stronger than the coffee at the top.

When the brewing cycle has been completed, five beeps will sound. Coffee will continue to stream from the filter for several seconds.

Never immerse base unit in water or other liquid. To clean base, simply wipe with a clean, damp cloth and dry before storing. Fingerprints and other blemishes on the stainless steel housing can be washed off with soap and water or a nonabrasive cleaning solution. Wipe resting plate with a clean, damp cloth. Never use rough, abrasive materials or cleansers to clean the resting plate. Do not dry the inside of the water reservoir with a cloth, as lint may remain.

#### Decalcification

Decalcification refers to the removal of calcium deposits which form over time on the metal parts of the coffeemaker.

For best performance from your Cuisinart Classic™ 12-Cup (1.8 L) Programmable Coffeemaker, decalcify the base unit from time to time. The frequency depends upon the hardness of your tap water and how often you use the coffeemaker. The flashing Clean light will indicate when you should clean your coffeemaker.

If the Clean light begins to flash when the coffeemaker is turned on, it is telling you that the calcium buildup is interfering with the functioning of your coffeemaker and the flavour of your coffee. To clean, fill the water reservoir to capacity with a mixture of 1/3 white vinegar and 2/3 water. Press the Clean button. When the self clean light glows, turn the coffeemaker on by pressing the on/off button. The Clean light will shine steadily. The coffeemaker is now in Clean mode. One cycle should be sufficient to adequately clean the coffeemaker. When the cycle is completed and the five beeps sound, the coffeemaker will shut off. Turn the coffeemaker on to see if the Clean light continues to flash. If it does, turn it off and then repeat the cleaning procedure with a fresh solution of vinegar and water.

If the Clean light no longer flashes, turn the coffeemaker off and then run one cycle of fresh cold water through the unit before using the unit again to brew coffee.

#### Notes on the Clean Function

Pressing the Clean button cancels all other settings. If it is pressed accidentally, press it again to return the coffeemaker to all its previous settings. Pressing On/Off will also exit the Clean Mode and turn the coffeemaker off.

## CLEANING AND MAINTENANCE

Always turn coffeemaker OFF and remove the plug from the electrical outlet before cleaning.

Lift up the reservoir cover. Remove and discard the paper filter and ground coffee. The filter basket can be washed in warm, soapy water and rinsed thoroughly, or cleaned in the upper rack of the dishwasher. Dry all parts after use.

**Do not put any water in the unit once the filter basket has been removed. Wipe the area under the filter basket with a damp cloth.**

Remove the carafe from the resting plate. Discard any remaining coffee. The carafe and lid can be washed in warm, soapy water and rinsed thoroughly, or placed in a dishwasher. The carafe and carafe lid should be placed on the upper rack only.

Do not use any scouring agents or harsh cleansers on any part of the coffeemaker.

## WARRANTY

### LIMITED THREE-YEAR WARRANTY

This warranty supersedes all previous warranties on the Cuisinart® Classic™ 12-Cup (1.8 L) Programmable Coffeemaker. This warranty is available to consumers only. You are a consumer if you own a Cuisinart® Classic™ 12-Cup (1.8 L) Programmable Coffeemaker that was purchased at retail for personal, family or household use. This warranty is not available to retailers or other commercial purchasers or owners.

We warrant that your Cuisinart® Classic™ 12-Cup (1.8 L) Programmable Coffeemaker will be free of defects in material or workmanship under normal home use for three years from the date of original purchase.

For warranty purposes, we would like to suggest that you register your product on-line at [www.cuisinart.ca](http://www.cuisinart.ca) to facilitate verification of the date of original purchase. However, should you not wish to register on-line we recommend the consumer to maintain original receipt indicating proof of purchase. In the event that you do not have proof of purchase date, the purchase date for purposes of this warranty will be the date of manufacture.

When calling our Authorized Service Centre for in warranty service please make reference to your model number and the manufacturing date code. This information can be found in the rating area on the body or underneath the base of your unit. The model number will follow the word Model: DCC1100C. The manufacturing date code is a 4 or 5 digit number sometimes followed by a letter. Example, 70630K would designate year, month & day (2007, June 30th).

If your coffeemaker should prove to be defective within the warranty period, we will repair it or, if we think it necessary, replace it. To obtain warranty service, please call our Consumer Service Centre toll-free at 1-800-472-7606 or write to:

Cuisinart  
100 Conair Parkway  
Woodbridge, Ont. L4H 0L2

To facilitate the speed and accuracy of your return, please also enclose \$10.00 for shipping and handling of the product. Please also be sure to include a return address, description of the product defect, product serial number, and any other information pertinent to the product's return. Please pay by cheque or money order.

**NOTE:** For added protection and secure handling of any Cuisinart® product that is being returned, we recommend you use a traceable, insured delivery service.

Cuisinart cannot be held responsible for in transit damage or for packages that are not delivered to us. Lost and/or damaged products are not covered under warranty.

Your Cuisinart® coffeemaker has been manufactured to strict specifications and has been designed for use with the Cuisinart® coffeemaker authorized accessories and replacement parts for your model.

These warranties expressly exclude any defects or damages caused by accessories, replacement parts or repair service other than those that have been authorized by Cuisinart. These warranties exclude all incidental or consequential damages.

#### BEFORE RETURNING YOUR CUISINART PRODUCT

**Important:** If the nonconforming product is to be serviced by someone other than Cuisinart's Authorized Service Centre, please remind the servicer to call our Consumer Service Centre to ensure that the problem is properly diagnosed, the product serviced with the correct parts, and to ensure that the product is still under warranty.

# Cuisinart®

S A V O R T H E G O O D L I F E®



Cuisinart offers an extensive assortment of top quality products to make life in the kitchen easier than ever. Try some of our other countertop appliances and cookware, and Savor the Good Life®.

[www.cuisinart.ca](http://www.cuisinart.ca)

©2007 Cuisinart  
Cuisinart® is a registered  
trademark of Cuisinart

100 Conair Parkway  
Woodbridge, Ont. L4H 0L2  
Consumer Call Centre E-mail:  
[Consumer\\_Canada@Conair.com](mailto:Consumer_Canada@Conair.com)

Printed in China

06CC25135

IB-7023-CAN